

Part names

Unit

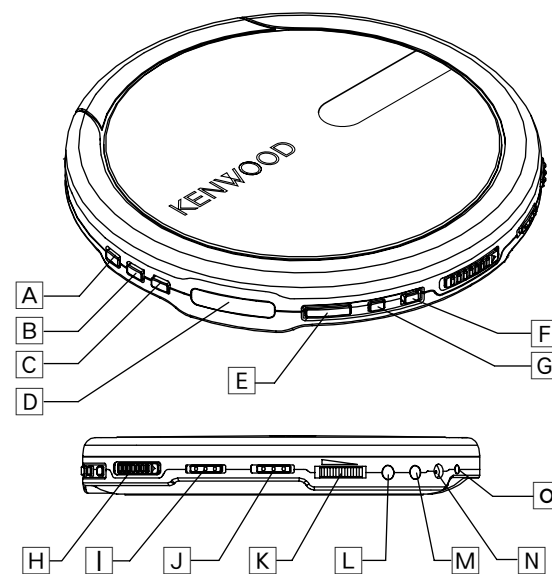

- A** D.A.S.C. (Digital Anti Shock Circuit) key
- B** P.MODE (Play mode) key
- C** PROGRAM key
- D** Display
- E** SKIP/SEARCH (Skip/Search) keys
- F** PLAY/PAUSE (Play/Pause) key
- G** STOP (Stop/Off) key
- H** OPEN switch (Slide to open top cover)
- I** HOLD switch
- J** B.BOOST (Bass Boost) key
- K** VOLUME control knob
- L** LINE OUT jack
- M** PHONES jack
- N** DC IN (External power) jack
- O** IND. (Battery charge) indicator

Display

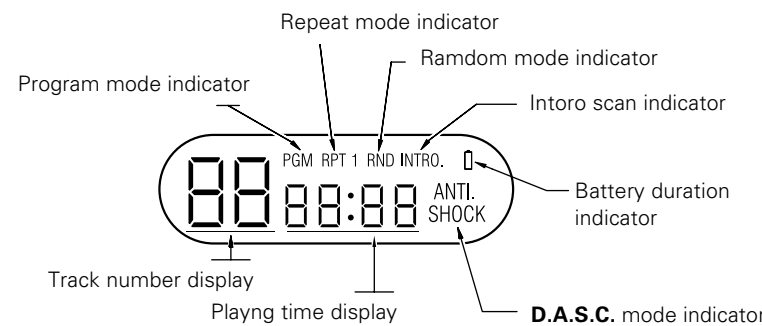

Specifications

Format	System	Compact disc digital audio system
	Laser	Semiconductor laser
Audio	Frequency response	20 Hz to 20 kHz, ± 3 dB
	PHONES output level (32Ω, 1 kHz)	9 mW + 9 mW
	Line output/impedance (BASS BOOST on)	0.48 Vrms/47 kΩ
Power supply	External DC supply	DC 4.5 V
	Rechargeable batteries (NB-3A70) x 2	DC 2.4 V
	Commercially-available alkaline batteries (LR03) x 2	DC 3.0 V

Battery life (Fully charge)	D.A.S.C. On	D.A.S.C. Off
	Rechargeable batteries (NB-3A70)	Approx. 6.5 Hours
Commercially-available alkaline batteries (LR03)	Approx. 10 Hours	Approx. 6.5 Hours

- At 0.1mW+0.1mW output (32Ω load).
- Standard value during continuous use/charging in an temperature of 20°C.
- Time of use may vary depending on battery maker, battery type, use environment, and temperature.

Dimensions (W x H x D) 137 mm x 20.5 mm x 137 mm (5- 3/8" x 13/16" x 5-3/8")
Weight (net) 171 g (6.0 oz)

Note:
KENWOOD follows a policy of continuous advancements in development. For this reason specifications may be changed without notice.

	For Europe	For other countries
AC adaptor	1	—
Rechargeable Batteries	2	—
Headphones	1	1

Separately sold option part
Rechargeable Nickel Metal Hydride Battery NB-3A70

KENWOOD For your records
Record the serial number, found on the back of the unit, in the spaces designated on the warranty card, and in the space provided below. Refer to the model and serial numbers whenever you call upon your dealer for information or service on this product.
Model _____ Serial Number _____

KENWOOD

PORTABLE CD PLAYER

DPC-X337

INSTRUCTION MANUAL

KENWOOD CORPORATION

Before using the rechargeable batteries: (For Europe)

- The rechargeable batteries comes non-charged condition. Read "Rechargeable battery operation" carefully and charge the batteries before use.

Unpacking

Unpack the unit carefully and make sure that all the accessories are present. If any accessories are missing, or if the unit is damaged or fails to operate, notify your dealer immediately. If the unit was shipped to you directly, notify your shipper immediately. Kenwood recommends that you retain the original carton and packing materials in case you need to move or ship the unit in the future.
Keep this manual handy for future reference.



B60-5389-08 00 (E,M) [AP] 0302

Safety precautions

Caution : Read this page carefully to ensure safe operation.

WARNING : TO PREVENT FIRE OR ELECTRIC SHOCK, DO NOT EXPOSE THIS APPLIANCE TO RAIN OR MOISTURE.

IMPORTANT SAFEGUARDS

Please read all of the safety and operating instructions before operating this appliance. Adhere to all warnings on the appliance and in the instruction manual. Follow all the safety and operating instructions. These safety and operating instructions should be retained for future reference.

- Power sources** — The appliance should be connected to a power supply only of the type described in the instruction manual or as marked on the appliance.
- Power-cord protection** — Power-supply cords should be routed so that they are not likely to be walked on or pinched by items placed upon or against them, pay particular attention to cords at plugs, convenience receptacles, and the point where they exit from the appliance.
- Enclosure removal** — Never remove the enclosure. If the internal parts are touched accidentally, a serious electric shock might occur.
- Drop** — Do not drop the appliance or apply strong shock to it. (Damage due to dropping the appliance is not covered by the warranty.)
- Ventilation** — Avoid hindering the ventilation of the appliance by covering it with a cloth, etc.
- Abnormal smell** — If an abnormal smell or smoke is detected, immediately turn the power OFF and pull out the power cord. Contact your dealer or nearest service center.
- Heat** — Avoid placing the appliance under direct sunlight or near a source of heat such as heating equipment. Particularly, never leave it in an automobile or on the dashboard.
- Temperature** — The appliance may not function properly if used at extremely low, or freezing temperatures. The ideal ambient temperature is above +5°C (41°F).
- Water and moisture** — The appliance shall not be exposed to dripping and splashing - for example, near a bathtub, washbowl, kitchen sink, laundry tub, in a wet basement, or near a swimming pool, etc.
- Dust and moisture** — Avoid places where is dusty or where the humidity is high.
- Vibrations** — Avoid placing the appliance on an unstable place such as a shelf or in a place subject to vibrations.
- Magnetic fields** — Keep the appliance away from sources of magnetic fields such as TV sets, speaker systems, radios, motorized toys or magnetized objects.
- Cleaning** — Unplug this appliance from the wall outlet before cleaning. Do not use volatile solvents such as alcohol, paint thinner, gasoline, or benzine, etc. to clean the cabinet. Use a clean dry cloth.
- Nonuse periods** — The power cord of the appliance should be unplugged from the outlet when left unused for a long period of time.
- Damage requiring service** — The appliance should be serviced by qualified service personnel when:
 - The power-supply cord or the plug has been damaged.
 - Objects have fallen, or liquid has been spilled into the appliance.
 - The appliance has been exposed to rain or water.
 - The appliance does not appear to operate normally by following the instruction manual. Adjust only those controls that are covered by the instruction manual as an improper adjustment of other controls may result in damage and will often require extensive work by a qualified technician to restore the appliance to its normal operation.
 - The appliance has been dropped, or the enclosure damaged.
 - The appliance exhibits a marked change in performance.
- Servicing** — The user should not attempt to service the appliance beyond that described in the instruction manual. All other servicing should be referred to qualified service personnel.
- CAUTION** — TO PREVENT ELECTRIC SHOCK DO NOT USE THE AC PLUG WITH AN EXTENSION CORD, RECEPTACLE OR OTHER OUTLET UNLESS THE BLADES CAN BE FULLY INSERTED TO PREVENT BLADE EXPOSURE.

Sound skip guard function (D.A.S.C.)

D.A.S.C. (Digital Anti Shock Circuit)

When the D.A.S.C. function is operating, about a 180 seconds portion of signals is always stored in memory. Consequently, when the unit receives an impact, playback will continue without interruption even if the signal from the light pickup is interrupted. "Wide CAPTURE" uses a method strong in regard to vibrations in the rotation direction in addition to the conventional D.A.S.C. function, so that the sound skip guard function is made even stronger.

Mechanism of D.A.S.C.

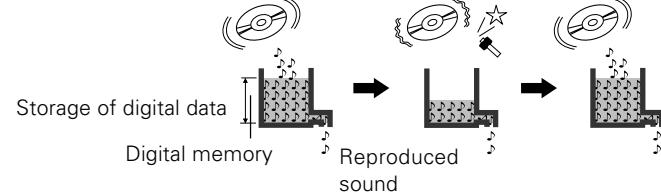

Setting the D.A.S.C.

The mode changes each time the D.A.S.C. key is pressed.

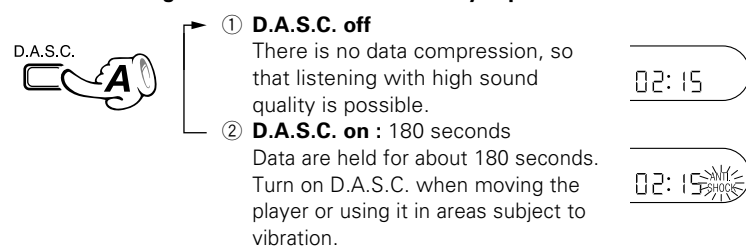

- Depending on the extent of the impact, the data in the memory may be used up, so the playback skip protection may momentarily be ineffective.
- When the D.A.S.C. function is activated, the disc may stop or start to rotate.
- The reproduced sound is interrupted during switching.
- The D.A.S.C. is set to on when the power turns on.

In case of difficulty

What seems to be a serious trouble may sometimes be due to a simple mistake. Before calling for service, check the items shown in the following table again. (If you request servicing due to the reasons shown in the table, the service may be charged in some cases.)

Symptom	Cause	Remedy
Pressing a key cannot initiate an operation or turn the unit on.	<ul style="list-style-type: none">The HOLD switch is set to on (HOLD On).The batteries are exhausted.	<ul style="list-style-type: none">Set the switch to off (HOLD Off).Replace the two alkaline batteries, or recharge the rechargeable batteries.
	<ul style="list-style-type: none">The disc is placed upside down.Condensation has occurred inside the unit.The AC adaptor is disconnected.	<ul style="list-style-type: none">Place the disc with the labeled side up.Leave the unit for about 1 hour before re-use.Connect it properly.
No sound is heard from the headphones.	<ul style="list-style-type: none">The headphones are connected incompletely.The headphones are connected to LINE OUT jackThe volume is set to the minimum position on the unit.	<ul style="list-style-type: none">Insert the plug securely into the PHONES jack.Insert the plug securely into the PHONES jack.Adjust the volume on the unit.
	<ul style="list-style-type: none">The D.A.S.C. is set to off.A strong vibration that exceeds the capacity of the D.A.S.C. has occurred.The disc is dirty.The lens is dirty.	<ul style="list-style-type: none">The D.A.S.C. is set to on.Place the unit in a place not subject to vibration.Clean it.The lens should be cleaned using a commercially available camera lens blower.Clean it.Replace or recharge the batteries.
Sound skips, or is interrupted.	<ul style="list-style-type: none">The headphone plug is dirty.The batteries are low.	<ul style="list-style-type: none">Clean it.Replace or recharge the batteries.
	<ul style="list-style-type: none">The headphones are connected incompletely.A source of strong magnetism or radio wave, such as a TV set or cellular phone, is present near the unit.	<ul style="list-style-type: none">Insert the plug securely into the PHONES jack.Install the unit away from a TV set, cellular phone, etc.
Noise interferes.	<ul style="list-style-type: none">The headphone plug is dirty.The batteries are low.The headphones are connected incompletely.A source of strong magnetism or radio wave, such as a TV set or cellular phone, is present near the unit.	<ul style="list-style-type: none">Clean it.Replace or recharge the batteries.Insert the plug securely into the PHONES jack.Install the unit away from a TV set, cellular phone, etc.
Rechargeable batteries cannot be recharged.	<ul style="list-style-type: none">Commercially available rechargeable batteries are used.	<ul style="list-style-type: none">Use the exclusive rechargeable batteries (NB-3A70).

Note :

- This system uses a microcomputer so it may malfunction due to external noise or interference. In such a case, unplug the power cord and remove the batteries, then re-connect the power cord and insert the batteries again.
- Erroneous operation may occur when the headphone plug is plugged or unplugged; but this is not a malfunction.

Maintenance

Simple care

Care of lens

When the lens in the pick-up gets dirty, malfunctions including the impossibility of playback may occur. The lens should be cleaned using a commercially available camera lens blower, etc. Do not touch the lens to prevent damaging the mechanism. Also do not use a lens cleaner or disc cleaner product.

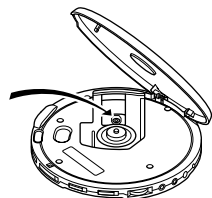

Care of main unit

When the unit gets dirty, clean with a soft, dry cloth. If the unit is stained seriously, a moistened cloth can be used. Do not use thinner, benzine, alcohol, etc. for these agents may cause discoloration.

Cleaning the plug

Wipe the headphone plug with a soft cloth to keep it clean. A dirty plug may cause noise or malfunction.

Caution on disc used

Usable discs

This unit is capable of playing back the Audio CD discs, CD-R/CD-RW (CD-DA) discs and discs carrying the **100%** marking. Other discs cannot be played. 8 cm single CDs can be played as they are; do not use a commercially-available single CD adapter.

- Certain CD-R/CD-RW discs may not be played due to recording conditions of the discs.

Handling

Hold compact discs so that you do not touch the playing surface. Do not attach paper or tape to either the playing side or the label side of compact discs.

Never play a cracked or warped disc.

During playback, the disc rotates at high speed in the player. Therefore, to avoid danger, never use a cracked or deformed disc or a disc repaired with tape or adhesive agent.

The marking of products using lasers (For countries other than U.S.A., U.S.-Military and Canada)

CLASS 1 LASER PRODUCT	The marking this product has been classified as Class 1. It means that there is no danger of hazardous radiation outside the product. Location: Back panel
------------------------------	---

Power sources

⚠ Caution: Read this page carefully to ensure safe operation.

This unit can be powered with 2 kinds of supplies including the batteries and household power line.

Using the AC adaptor (For Europe)

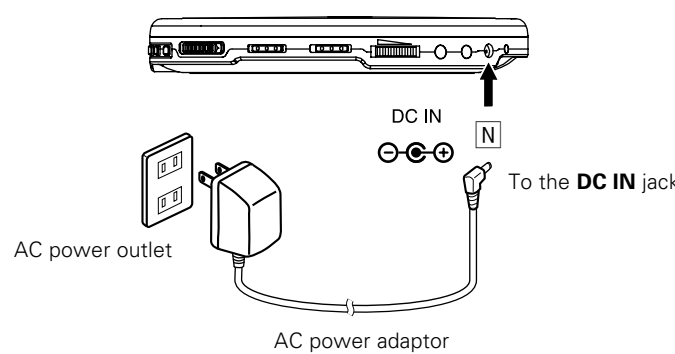

- Use the enclosed AC adaptor for this product.

When operating the unit with 2 alkaline batteries (Alkaline batteries are not provided with this unit)

- Open the battery cover.
- Insert 2 alkaline batteries and close the cover.



- Make sure the positive (+) and negative (-) poles are properly aligned.
- Use commercially available LR03 batteries. The unit may not operate normally if manganese batteries are used.
- Replace both batteries at the same time.

Never use an alkaline battery and non-alkaline battery together.

Battery duration indicator

The duration at which the battery indicator starts to blink is variable depending on the type of battery used.

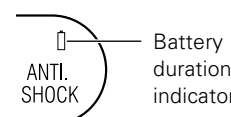

Battery Type	Blinking Timing	Treatment
Rechargeable batteries	When the batteries is nearly exhausted.	In a while, the power will be turned off automatically. Then recharge the batteries.
Alkaline batteries	When the batteries are half exhausted.	Playback is possible while the indicator is blinking.

Rechargeable battery operation (For Europe)

Always use the specially provided rechargeable batteries NB-3A70. Never use the batteries other than the batteries authorized by Kenwood.

Loading the batteries

- Open the battery cover.
- Insert 2 rechargeable batteries and close the cover.



- Make sure the positive (+) and negative (-) poles are properly aligned.

Charging the rechargeable batteries

- Plug in the AC adaptor to start charging.
- After the batteries have been charged, remove the AC adaptor.

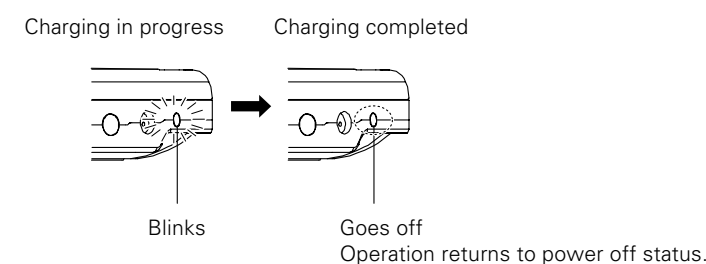

- When using a rechargeable battery which is new or which has not been used for more than 2 months, the operating period may be shorter than normal. This is due to the properties of the battery and not a malfunction. After recharging, use the battery on the unit until it is exhausted. The original performance of the battery performance can be recovered by repeating this cycle a few times.
- Be sure to close the top cover of the unit before proceeding to recharging.
- Recharging completes in about 12 hours. Do not attempt to recharge the batteries after this period.
- Rechargeable batteries can be recharged. When the playable time per recharge reduces, please newly purchase the optional (NB-3A70) rechargeable batteries.

Never use a rechargeable battery and non-rechargeable battery together.

Playback from the first track

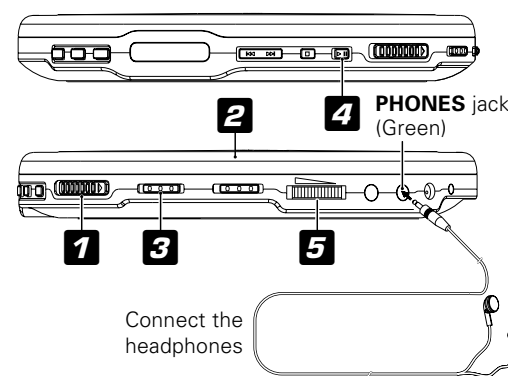

- Set the HOLD switch to off.

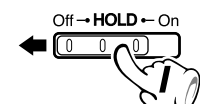

- For the Hold function, read "Hold function".
- Before any operation, be sure to set the HOLD switch to off (HOLD Off).

- When transporting the unit, it is recommended to set the HOLD switch in advance. In this way you can prevent unintended operation even when a key is pressed accidentally.

- Start playback.

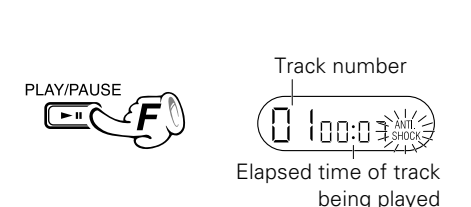

- The power comes on and playback begins.

- Adjust the volume.

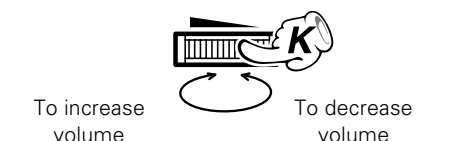

- Slide the OPEN switch in the direction of the arrow to open the top cover.

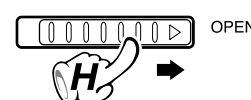

- Insert disc and close the top cover.

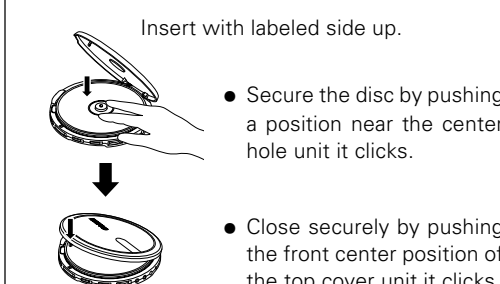

Playback from desired track

Skipping tracks

Press the SKIP/SEARCH key or key.

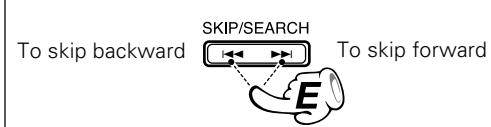

- When the SKIP/SEARCH key is pressed, playback will skip to the start of the subsequent track.
- Each time the key is pressed, playback will skip to the next track.
- When the SKIP/SEARCH key is pressed, playback will skip to the start of the track being played back.
- Each time the key is pressed, playback will skip to the previous track.

Fast forward, fast reverse

Hold the SKIP/SEARCH key or key pressed during playback.

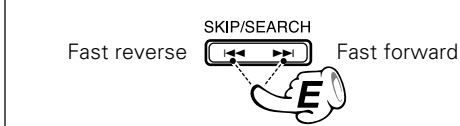

- Fast forward is engaged by pressing and holding down key SKIP/SEARCH while playback is in progress.
- Fast reverse is engaged by pressing and holding down key SKIP/SEARCH while playback is in progress.
- Playback will resume when either key is released.

Selecting Play Mode

Press during playback or stop status.

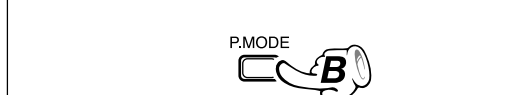

The mode changes each time the P.MODE key is pressed.

- One-track repeat**
The track being played or the selected track will be played repeatedly.
- All-track repeat**
All tracks on the disc will be played repeatedly.
- Intro Scan**
The disc will then begin playing the first ten seconds of all tracks once and then stops automatically.
- Random play**
All tracks on the disc will be played in a random order.
- Return to normal playback is made.

- If Intro Scan or Random Play is selected while playback is in progress, Intro Scan or Random Play operation will commence when the track being played back is over.

To pause playback temporarily

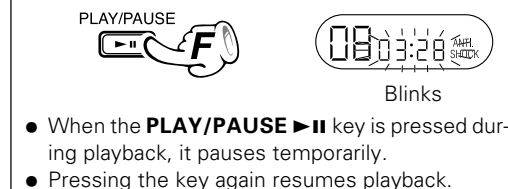

- When the PLAY/PAUSE key is pressed during playback, it pauses temporarily.
- Pressing the key again resumes playback.

To stop playback

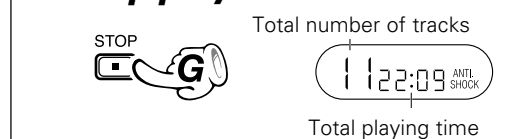

- The total number of tracks and the total playing time of them will be displayed.
- When a disc is inserted and the top cover is closed in stop mode, playback starts automatically.

To turn power off



Auto power-off function

If no operation key has been pressed for 30 seconds while the unit is in the stop mode, the power is turned off automatically to prevent battery power consumption.

Programming tracks in desired order

Favorite tracks (max. 20 tracks) can be programmed in the desired order during stop mode for later playback.

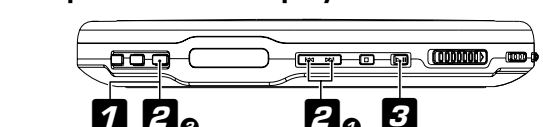

- Press the PROGRAM key

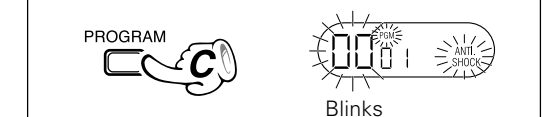

- Select the desired track numbers in the order you want to play them.

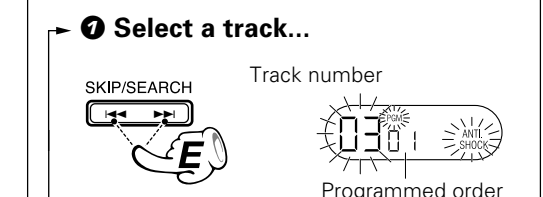

- and enter it.

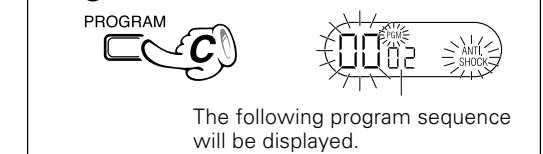

The following program sequence will be displayed.

- Repeat steps 1 and 2 and enter the Track Nos. into the program in order.
- Up to 20 tracks can be programmed in this unit, but not more than 20 tracks.

- Start playback.



Connections

Ensure that the power of all components is off before connecting the cords.

Listening through car audio

- Connect this unit with a commercially available car audio cassette adaptor and insert it into the car audio as shown. For details connection method, read the instruction manual for the car audio cassette adaptor.

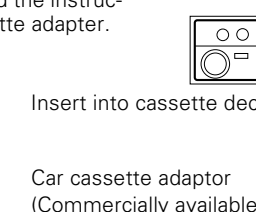

Listening through speakers

Speakers with built-in amplifier

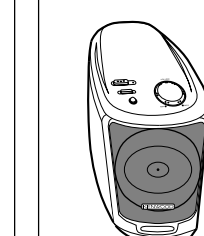

Listening through an amplifier with CD input jack

- Connect the cable to the amplifier's CD input jacks.
- This connection may be impossible with some amplifiers.

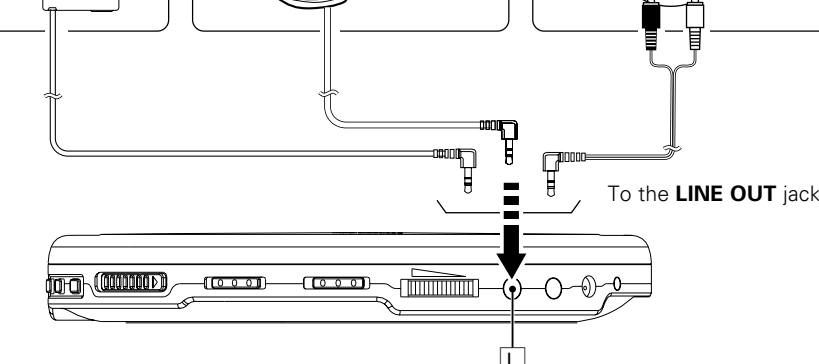
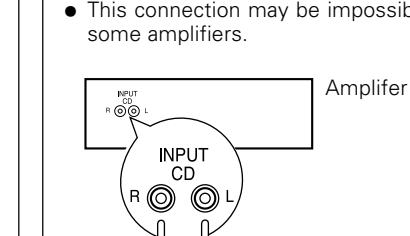

Notes:

- Adjust the listening volume on the connected audio component.
- Make sure to switch BASS BOOST off. (The tone should be adjusted only on the connected audio component.)